



HK-Belle 751

new model (1.7 t class)

751

- More than 500 kgs operating load
- Power performance, but compact in size, only 1,3 m wide
- Excellent ground clearance (22,8 cm) reach over height of 2,7 m
- 3-cylinder Yanmar diesel-engine provides the power for ultimate performance
- 500 cm³ wheel motors of high torque at reduced temperatures
- Hydraulic brakes, maintenance free
- Increasing existant range



HK-Belle Skid Steer



QUATTROSTATIC[®] THE ULTIMATE DRIVE

- driven by 4 hydrostatic wheel motors (no chains!)□
- minimized service requirements□
- metric engineering□
- EC quality product□
- powder coating colourization□
- lots of further advantages□
- market leading future technology, available now

technical data 751

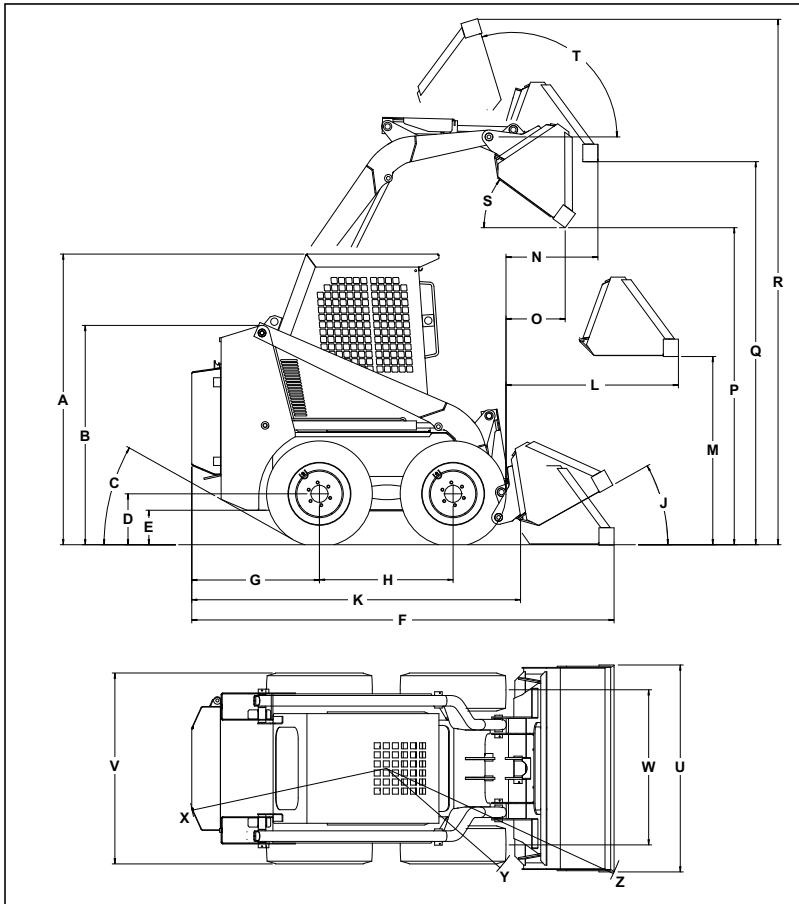

	mm	ft, inches
A	1925	6.3
B	1452	4.8
C	30°	30°
D	337	1.1
E	228	0.7
F	2796	9.2
G	845	2.8
H	885	2.9
I	25	0.1
J	30°	30°
K	2177	7.2
L	1142	3.7
M	1246	4.1
N	608	2
O	392 / 36°	1.2 / 36°
P	2099 / 36°	6.9 / 36°
Q	2700	8.8
R	3479	11.4
S	36°	36°
T	107°	107°
U	1370	4.5
V	1265	4.2
W	1027	3.4
X	1315	4.3
Y	1000	3.3
Z	1656	5.5

751

ENGINE (Diesel, watercooled, direct-injection, noise reduced and clean)

manufacturer / model	Yanmar3TNE84
no. of cylinders / displacement	3 / 1496 cm ³
power acc. to SAE J1349 / speed	23 kw (30.8 hp) / 2800 rpm
fuel tank capacity	45 l (9.9 gallons)

HYDRAULIC SYSTEM

pressure relief	185 b (2683 psi)
hydraulic flow (standard system + auxiliary)	40 l/min (10.55 galls/min)
hydraulic system capacity	45 l (9.9 gallons)

PERFORMANCE

rated operating load (SAE)	510 kgs (1122 lbs)
tipping load (SAE)	1020 kgs (2244 lbs)
breakout force (SAE) lift	984 kgs (2165 lbs)
(SAE) bucket	1120 kgs (2464 lbs)
operating weight*	1700 kgs (3740 lbs)
travel speed, stepless (forward & reverse)	11 km/h (6.8mph)
noise level operator's ear	90 LPA
sound power	104 LWA
standard tyres	27/10.5 x 15 - 8 ply
bucket-riding time @ full rated load / lowering time / dumping time / roll back time	4,4 s / 2,6 s / 2,2 s / 1,6 s
shipping weight	1475 kg (3245 lbs)

BUCKET CAPACITY (STANDARD)

struck (SAE J742)	0.21 m ³
heaped (SAE J742)	0.26 m ³

* incl. 79.5 kgs operator's weight, standard bucket and full fuel tank. SAE = Society of Automotive Engineers

Comprehensive variety of attachments and special equipment available. Please ask your authorized HK-Belle dealer!

appropriate dealer:

Horst Kümme! Handels GmbH □
 HK-Belle Marketing & Exports □
 Grüner Weg 44 • D-40229 Düsseldorf □
 Phone: +49 (0)211 72 40 07 □
 Fax: +49 (0)211 72 16 66 □
 e-mail: office@hk-baumaschinen.de